

BJ Series

Compact and Long Sensing Distance Type

■ Features

■ Long distance sensing type

- High performance lens with long sensing distance
 - Through-beam type: 15m
 - Diffuse reflective type: 1m
 - Polarized retroreflective type: 3m (MS-2A)
- M.S.R. (Mirror Surface Rejection) function (polarized retroreflective type) for detecting mirrors or highly reflective targets
- Compact size: W10.6 × H32 × L20mm
- Light ON/Dark ON operation mode switch
- Sensitivity adjuster
- Built-in reverse polarity protection circuit and output short overcurrent protection circuit
- Mutual interference prevention function (except through-beam type)
- Excellent noise immunity and minimal influence from ambient light
- IP65 protection structure (IEC standard) / IP67 for BJ-C connector types

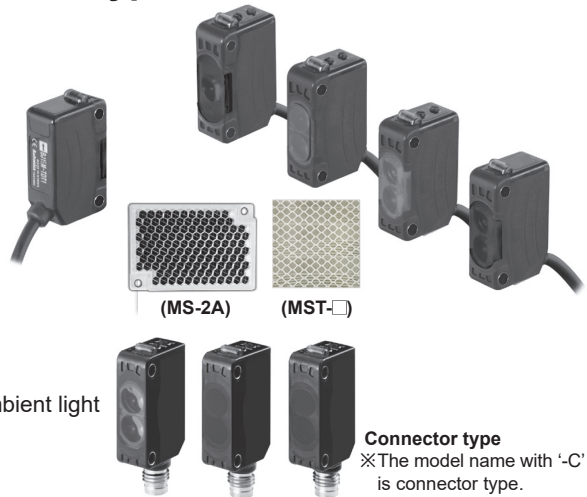

Connector type

- ※The model name with 'C' is connector type.
- ※MST-□ is sold separately.

⚠ Please read "Safety Considerations" in the instruction manual before using.



■ Specifications

| Type | Long distance sensing type | | | | | | | |
|------------------------|--|--|------------------------------|-------------------------------|--|---------------------|--|---------------|
| Model | NPN open collector output | BJ15M-TDT | BJ10M-TDT | BJ7M-TDT | BJ3M-PDT | BJ1M-DDT | BJ300-DDT | BJ100-DDT |
| | PNP open collector output | BJ15M-TDT-C | BJ10M-TDT-C | BJ7M-TDT-P | BJ3M-PDT-C | BJ1M-DDT-C | BJ300-DDT-C | BJ100-DDT-C |
| Model | NPN open collector output | BJ15M-TDT-P | BJ10M-TDT-P | BJ7M-TDT-P | BJ3M-PDT-P | BJ1M-DDT-P | BJ300-DDT-P | BJ100-DDT-P |
| | PNP open collector output | BJ15M-TDT-C-P | BJ10M-TDT-C-P | BJ7M-TDT-P | BJ3M-PDT-C-P | BJ1M-DDT-C-P | BJ300-DDT-C-P | BJ100-DDT-C-P |
| Sensing type | Through-beam | | | | Polarized retroreflective type | Diffuse reflective | | |
| Sensing distance | 15m | 10m | 7m | 3m ^{※1} | 1m ^{※2} | 300mm ^{※3} | 100mm ^{※3} | |
| Sensing target | Opaque material of min. Ø12mm | | Opaque material of min. Ø8mm | Opaque material of min. Ø75mm | Translucent, opaque materials | | | |
| Hysteresis | — | | | | | | | |
| Response time | Max. 1ms | | | | | | | |
| Power supply | 12-24VDC \pm 10% (ripple P-P: max.10%) | | | | | | | |
| Current consumption | Emitter/Receiver: Max. 20mA | | | | Max. 30mA | | | |
| Light source | Infrared LED (850nm) | Red LED (660nm) | Red LED (650nm) | Red LED (660nm) | Infrared LED (850nm) | Red LED (660nm) | Infrared LED (850nm) | |
| Sensitivity adjustment | Sensitivity adjuster | | | | | | | |
| Operation mode | Light ON/Dark ON operation mode switch | | | | | | | |
| Control output | NPN or PNP open collector output ●Load voltage: max. 26.4VDC \pm ●Load current: max. 100mA ●Residual voltage - NPN: max. 1VDC \pm , PNP: max. 2.5VDC | | | | | | | |
| Protection circuit | Reverse polarity protection circuit, output short overcurrent protection circuit, mutual interference prevention function (except through-beam type) | | | | | | | |
| Indicator | Operation indicator: red LED, stable indicator: green LED (emitter's power indicator: green) | | | | | | | |
| Insulation resistance | Over 20MΩ (at 500VDC megger) | | | | | | | |
| Noise immunity | \pm 240V the square wave noise (pulse width:1μs) by the noise simulator | | | | | | | |
| Dielectric strength | 1000VAC 50/60Hz for 1minute | | | | | | | |
| Vibration | 1.5mm amplitude at frequency of 10 to 55Hz (for 1 min) in each X, Y, Z direction for 2 hours | | | | | | | |
| Shock | 500m/s ² (approx. 50G) in each X, Y, Z direction for 3 times | | | | | | | |
| Environment | Ambient illumination | Sunlight: max. 11,000lx, incandescent lamp: max. 3,000lx (receiver illumination) | | | | | | |
| | Ambient temperature | -25 to 55°C, storage: -40 to 70°C | | | | | | |
| | Ambient humidity | 35 to 85%RH, storage: 35 to 85%RH | | | | | | |
| Protection structure | BJ: IP65 (IEC standard), BJ-C: IP67 (IEC standard) | | | | | | | |
| Material | Case: polycarbonate+acrylonitrile butadiene styrene, LED cap: polycarbonate, sensing part: polymethyl methacrylate, bracket: SUS304 (steel use stainless 304), bolt, nut: steel chromium molybdenum, sleeve: brass, ni-plate | | | | | | | |
| Cable ^{※4} | BJ: Ø3.5mm, 3-wire, 2m (emitter of through-beam type: Ø3.5mm, 2-wire, 2m) (AWG24, core diameter: 0.08mm, number of cores: 40, insulator out diameter: Ø1mm) | | | | | | | |
| Accessory | Common | Fixing bracket ^{※5} , M3 bolt: 4, M3 nut: 4, adjustment screwdriver | | | Fixing bracket ^{※5} , M3 bolt: 2, M3 nut: 2, adjustment screwdriver | | | |
| | Individual | — | | | Reflector (MS-2A) — | | | |
| Approval | CE | | | | | | | |
| Weight ^{※6} | BJ: approx. 115g (approx. 90g) BJ-C: approx. 45g (approx. 20g) | | | | BJ: approx. 85g (approx. 60g) BJ-C: approx. 55g (approx. 30g) | | BJ: approx. 70g (approx. 45g) BJ-C: approx. 35g (approx. 10g) | |

※1: The sensing distance is specified with the MS-2A reflector. The distance between the sensor and the reflector should be set over 0.1m.
The sensing distance is extended from 0.1 to 4m or 0.1 to 5m when using optional reflector MS-2S or MS-3S.
When using reflective tapes, the reflectivity will vary by the size of the tape. Please refer to the "■ Reflectivity By Reflective Tape Model" table before using the tapes.
※2: Non-glossy white paper 300×300mm. ※3: Non-glossy white paper 100×100mm.
※4: M8 connector cable is sold separately. (cable - AWG22, Core diameter: 0.08mm, Number of cores: 60, Insulator out diameter: Ø1.25mm)
※5: Cable type includes bracket A and connector type includes bracket B. ※6: The weight includes packaging. The weight in parenthesis is for unit only.
※The temperature or humidity mentioned in Environment indicates a non freezing or condensation environment.

Long Sensing Distance/BGS Reflective/Micro Spot Type

Transparent Glass Sensing/BGS Reflective/Micro Spot Type

■ Features

■ BGS reflective type

- BGS (background suppression) minimizes detection errors from background objects and the color or material of target objects. Also the detecting distance can be configured with the sensitivity adjuster.
- Visible light source allows users to identify the sensing area, and the tiny spot size minimizes influence from surrounding objects

■ Transparent glass sensing type / Micro spot type

- Stable detection of transparent targets (LCD, PDP, glass etc.) (transparent glass sensing types)
- Check sensing area with visible micro spot (micro spot types)
- Detect tiny objects (minimum target size: Ø0.2mm copper wire)

■ Commonness

- Compact size: W10.6 × H32 × L20mm
- Light ON/Dark ON operation mode switch (except BJG30-DDT)
- Sensitivity adjuster (except BJG3-DDT)
- Built-in reverse polarity protection circuit and output short overcurrent protection circuit
- Mutual interference prevention function (except BGS reflective type)
- Excellent noise immunity and minimal influence from ambient light
- IP65 protection structure (IEC standard)

⚠ Please read "Safety Considerations" in the instruction manual before using.

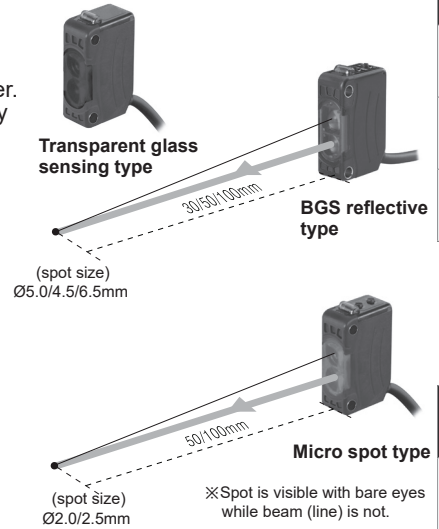

■ Specifications

| Type | Transparent glass sensing type | | BGS reflective type ^{※1} | | Micro spot type | |
|------------------------------------|--|--|--|--------------------------|-----------------------------------|------------------------------|
| Model | BJG30-DDT | | BJ30-BDT | BJ50-BDT | BJN50-NDT | BJN100-NDT |
| | — | | BJ30-BDT-P | BJ50-BDT-P | BJN50-NDT-P | BJN100-NDT-P |
| Sensing type | Diffuse reflective | | BGS reflective | | Narrow beam reflective | |
| Sensing distance | 30mm ^{※2} | 15mm ^{※3} | 10 to 30mm ^{※4} | 10 to 50mm ^{※4} | 30 to 70mm | 70 to 130mm |
| Sensing target | Transparent glass, opaque materials, translucent | | Translucent, opaque materials | | Translucent, opaque materials | |
| Min. diameter of transmitting spot | — | | Approx. Ø5.0mm | Approx. Ø4.5mm | Approx. Ø2.0mm | Approx. Ø2.5mm |
| Min. sensing target | — | | — | | Approx. min. Ø0.2mm (copper wire) | |
| Hysteresis | Max. 20% at sensing distance | | Max. 10% at sensing distance | | Max. 25% at sensing distance | Max. 20% at sensing distance |
| Response time | Max. 1ms | | Max. 1.5ms | | Max. 1ms | |
| Power supply | 12-24VDC [≡] ±10% (ripple P-P: max.10%) | | | | | |
| Current consumption | Max. 30mA | | | | | |
| Light source | Infrared LED (850nm) | | Red LED (660nm) | | Red LED (650nm) | |
| Sensitivity adjustment | — | | Sensitivity adjuster | | | |
| Operation mode | Light ON fixed | | Light ON/Dark ON operation mode switch | | | |
| Control output | NPN open collector output ●Load voltage: max. 26.4VDC [≡] ●Load current: max. 100mA ●Residual voltage: max. 1V | | NPN or PNP open collector output ●Load voltage: max. 26.4VDC [≡] ●Load current: max. 100mA ●Residual voltage - NPN: max. 1VDC [≡] , PNP: min. 2.5VDC | | | |
| Protection circuit | Reverse polarity protection circuit, output short overcurrent protection circuit, mutual interference prevention function (except BGS reflective type) | | | | | |
| Indicator | Operation indicator: red LED, stability indicator: green LED | | | | | |
| Insulation resistance | Over 20MΩ (at 500VDC megger) | | | | | |
| Noise immunity | ±240V the square wave noise (pulse width:1μs) by the noise simulator | | | | | |
| Dielectric strength | 1,000VAC 50/60Hz for 1 min | | | | | |
| Vibration | 1.5mm amplitude at frequency of 10 to 55Hz (for 1 min) in each X, Y, Z direction for 2 hours | | | | | |
| Shock | 500m/s ² (approx. 50G) in each X, Y, Z direction for 3 times | | | | | |
| Environment | Ambient illumination | Sunlight: max. 11,000lx, incandescent lamp: max. 3,000lx (receiver illumination) | | | | |
| | Ambient temperature | -25 to 55°C, storage: -40 to 70°C | | | | |
| | Ambient humidity | 35 to 85%RH, storage: 35 to 85%RH | | | | |
| Protection structure | IP65 (IEC standard) | | | | | |
| Material | Case: polycarbonate+acrylonitrile butadiene styrene, LED cap: polycarbonate, sensing part: polymethyl methacrylate, bracket: SUS304 (steel use stainless 304), bolt, nut: steel chromium molybdenum, sleeve: brass, ni-plate | | | | | |
| Cable | Ø3.5mm, 3-wire, 2m (AWG24, core diameter: 0.08mm, number of cores: 40, insulator out diameter: Ø1mm) | | | | | |
| Accessory | Fixing bracket, M3 bolt: 2, M3 nut: 2 | | Fixing bracket, M3 bolt: 2, M3 nut: 2, adjustment screwdriver | | | |
| Approval | CE | | | | | |
| Unit weight | Approx. 45g | | Approx. 50g | | Approx. 45g | |

※1: In case of BGS sensing type, black/white difference is max. 10% of sensing distance and sensitivity adjustment range is -10% of max. sensing distance (based on non-glossy white paper).

※2: Non-glossy white paper 100×100mm.

※3: Transparent glass 50×50mm, t=3.0mm.

※4: Non-glossy white paper 50×50mm.

※The temperature or humidity mentioned in Environment indicates a non freezing or condensation environment.

SENSORS

CONTROLLERS

MOTION DEVICES

SOFTWARE

(A) Photoelectric Sensors

(B) Fiber Optic Sensors

(C) LIDAR

(D) Door/Area Sensors

(E) Vision Sensors

(F) Proximity Sensors

(G) Pressure Sensors

(H) Rotary Encoders

(I) Connectors/ Connector Cables/ Sensor Distribution Boxes/ Sockets

BJ Series

■ Feature Data

◎ Through-beam type

● BJ15M-TDT- (C)- (P) / BJ10M-TDT- (C)- (P) / BJ7M-TDT- (P)

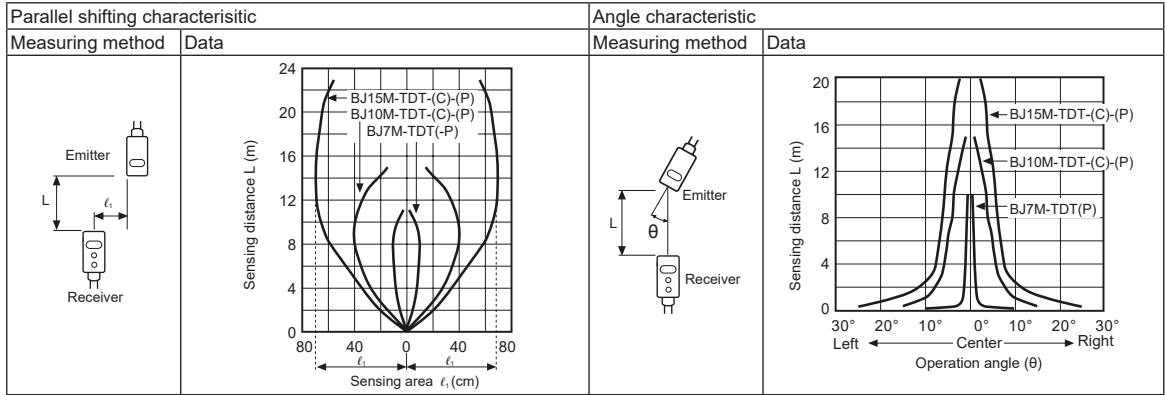

◎ Retroreflective type

● BJ3M-PDT- (C)- (P)

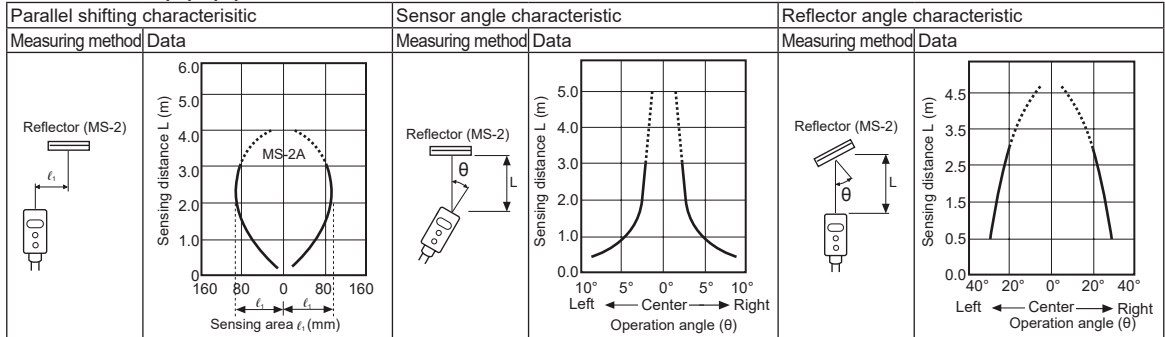

◎ Diffuse/Narrow beam reflective type

● BJ1M-DDT- (C)- (P)

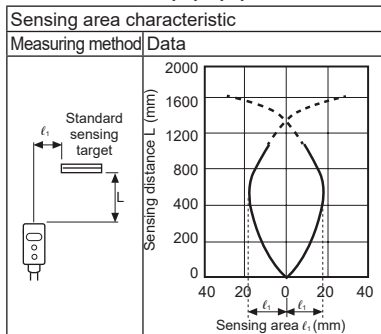

● BJ300-DDT- (C)- (P)

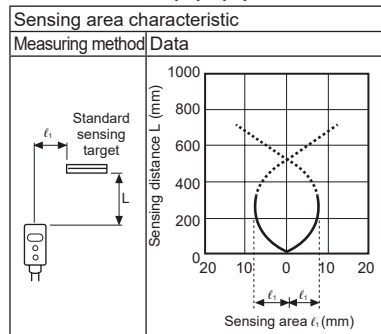

● BJ100-DDT- (C)- (P)

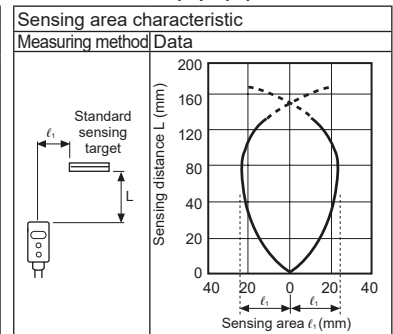

● BJG30-DDT

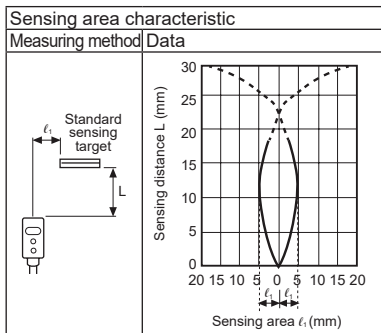

● BJN50-NDT- (P)

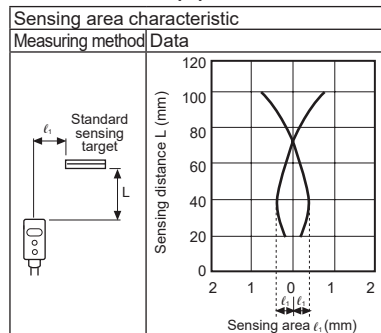

● BJN100-NDT- (P)

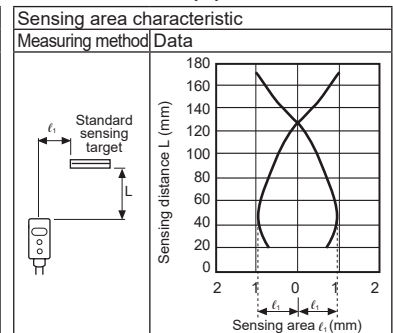

Long Sensing Distance/BGS Reflective/Micro Spot Type

Feature Data

◎ BGS reflective type

● BJ30-BDT / BJ30-BDT-P

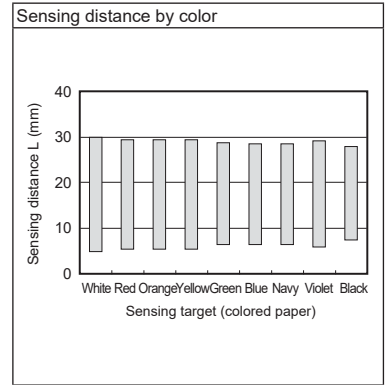
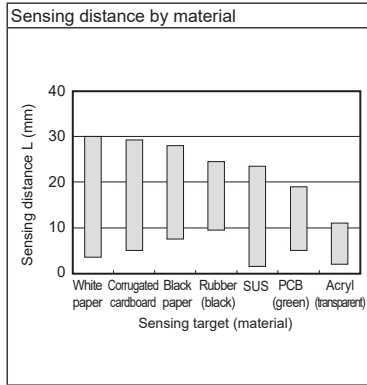
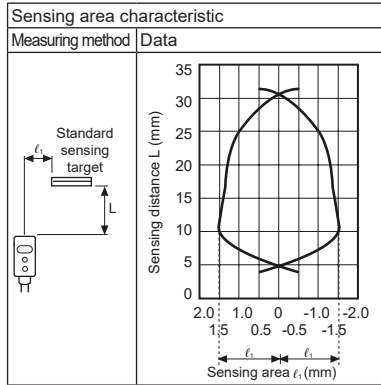

● BJ50-BDT / BJ50-BDT-P

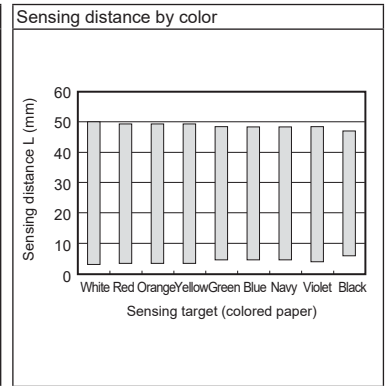
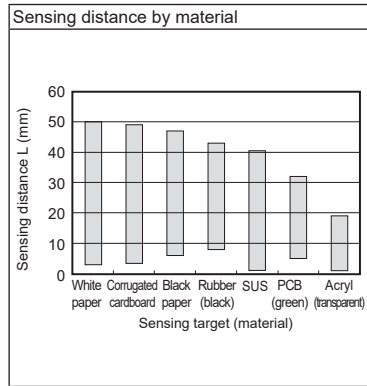
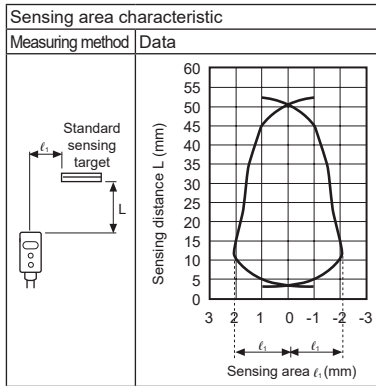

Connections

● Through-beam type

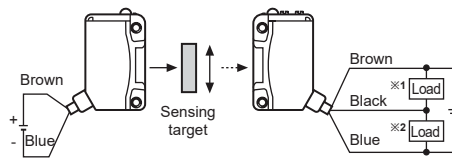

● Retroreflective type

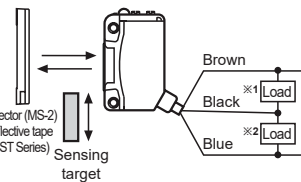

● Diffuse/Narrow beam/BGS reflective type

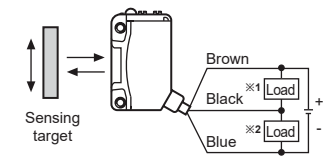

※1: Load connection for NPN output
 ※2: Load connection for PNP output

Connections for Connector Part

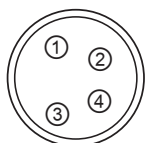

M8 Connector pin

| Connector pin No. | Cable colors | Function |
|-------------------|--------------|-------------------|
| ① | Brown | Power Source (+V) |
| ② | White | — |
| ③ | Blue | Power Source (0V) |
| ④ | Black | Output |

※Connector pin ② is N·C (not connected) terminal.

● Connector cable (sold separately)

※Connector cable model
 : CID408-□, CLD408-□
 ※Please refer to the connector cable section.

SENSORS

CONTROLLERS

MOTION DEVICES

SOFTWARE

(A) Photoelectric Sensors

(B) Fiber Optic Sensors

(C) LIDAR

(D) Door/Area Sensors

(E) Vision Sensors

(F) Proximity Sensors

(G) Pressure Sensors

(H) Rotary Encoders

(I) Connectors/ Connector Cables/ Sensor Distribution Boxes/ Sockets

BJ Series

Control Output Diagram

• NPN open collector output

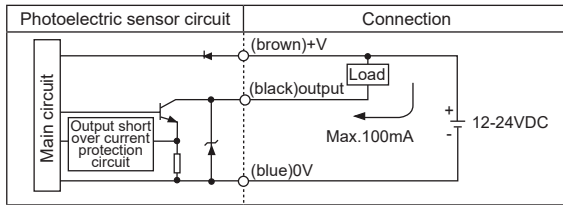

• PNP open collector output

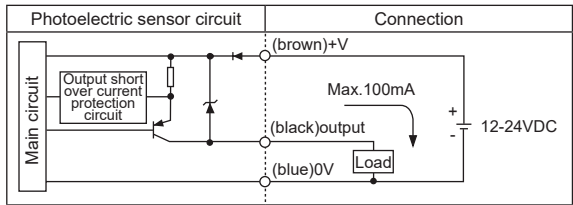

※If short-circuit the control output terminal or supply current over the rated specification, normal control signal is not output due to the output short over current protection circuit.

Operation Mode

| Operation mode | Light ON | Dark ON |
|-------------------------------|-------------------------------------|-------------------------------------|
| Receiver operation | Received light Interrupted light | Received light Interrupted light |
| Operation indicator (red LED) | ON OFF | ON OFF |
| Transistor output | ON OFF | ON OFF |

Dimensions

(unit: mm)

• Through-beam type

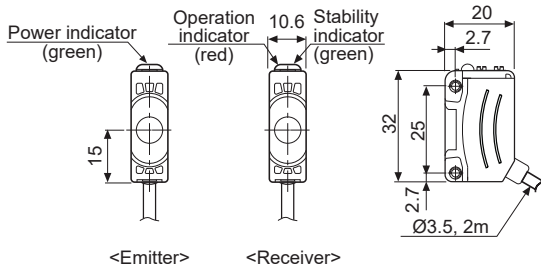

• Through-beam type (connector type)

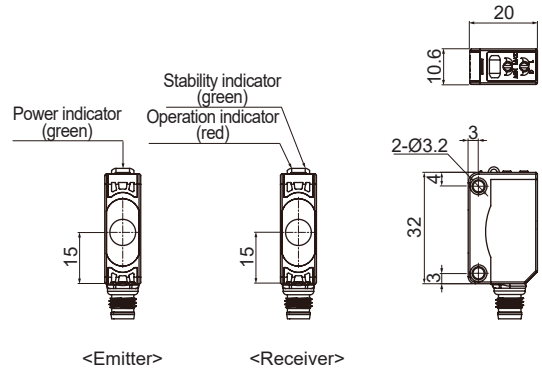

• Retroreflective type

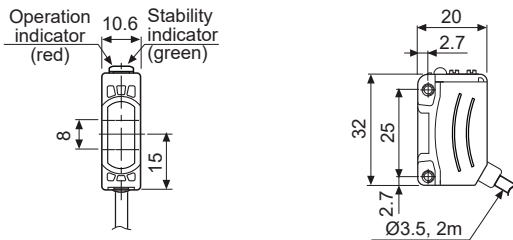

• Retroreflective type (connector type)

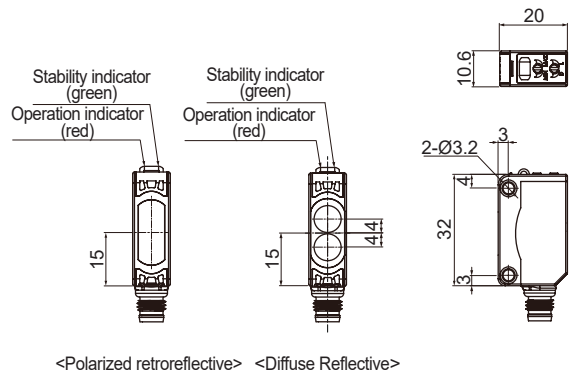

Long Sensing Distance/BGS Reflective/Micro Spot Type

• Reflector(MS-2A)

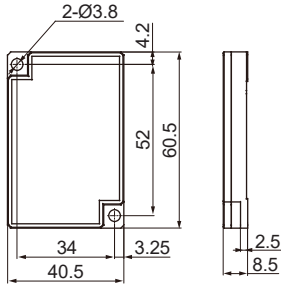

• Bracket A

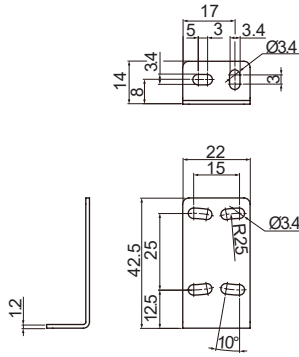

• Bracket B

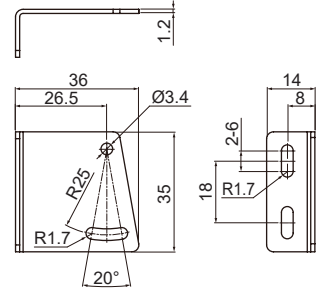

※Cable type provides the bracket A and connector type provides the bracket B.
The other bracket is also available as sold separately.

• Reflective tape (sold separately)

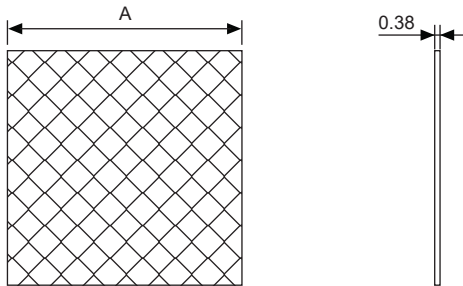

(unit: mm)

| Model | A |
|-----------|------------------------------|
| MST-50-10 | <input type="checkbox"/> 50 |
| MST-100-5 | <input type="checkbox"/> 100 |
| MST-200-2 | <input type="checkbox"/> 200 |

■ Operation Timing Diagram

• Through-beam type

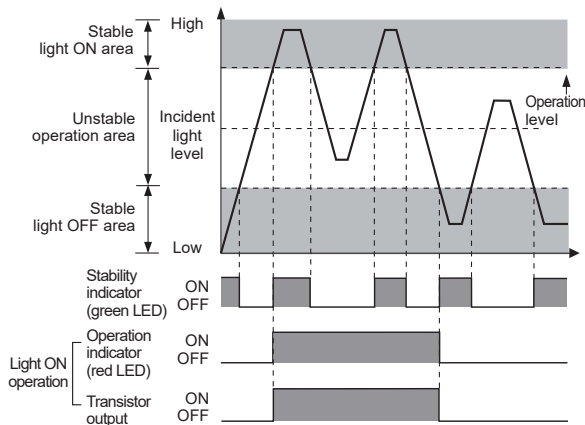

• Retroreflective/Diffuse/Narrow beam/BGS reflective type

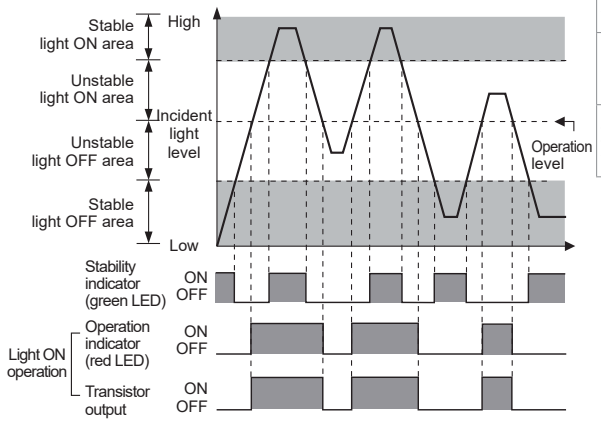

※The waveforms of "Operation indicator" and "Transistor output" are for Light ON operation.
They are opposite operation for Dark ON operation.

■ Mounting and Adjustment

◎ For mounting

When using the reflective type photoelectric sensors closely over three units, it may result in malfunction due to mutual interference.

When using the through-beam type photoelectric sensors closely over two units, it may result in malfunction due to mutual interference.

When installing the product, tighten the screw with a tightening torque of 0.5N·m.

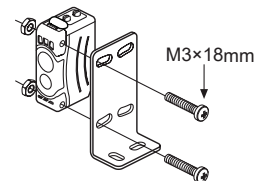

SENSORS

CONTROLLERS

MOTION DEVICES

SOFTWARE

(A) Photoelectric Sensors

(B) Fiber Optic Sensors

(C) LIDAR

(D) Door/Area Sensors

(E) Vision Sensors



(F) Proximity Sensors

(G) Pressure Sensors

(H) Rotary Encoders

(I) Connectors/ Connector Cables/ Sensor Distribution Boxes/ Sockets

◎ Switching of operation mode

| | | |
|--------------------|---|--|
| Light ON operation |  | Turn the operation mode switch to the end of right (L direction), it is set as Light ON. |
| Dark ON operation |  | Turn the operation mode switch to the end of left (D direction), it is set as Dark ON. |

※For through-beam type, the operation mode switch is built-in the receiver.

◎ Optical axis adjustment

● Through-beam type

- Place the emitter and the receiver facing each other and supply the power.
- After adjusting the position of the emitter and the receiver and checking their stable indicating range, mount them in the middle of the range.

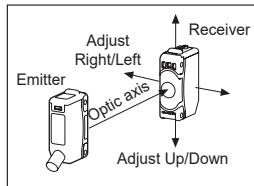

- After mounting this unit, check the operation of the sensor and lighting of the stability indicator in both status. (none or sensing target status)

※When the sensing target is translucent or small (under sensing target of '■ Specifications'), it may not be detected by the sensor because the light can penetrate it.

● Retroreflective type

- Place the sensor and the reflector (or reflective tape) facing each other and supply the power.
- After adjusting the position of the sensor and reflector (or reflective tape) and checking their stable indicating range, mount them in the middle of the range. (none or sensing target status)
- After mounting this unit, check the operation of the sensor and in both status. (none or sensing target status)

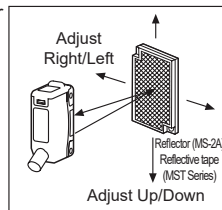

※Please use reflective tape (MST Series) for where a reflector is not installed.

● Diffuse/Narrow beam/BGS reflective type

After placing a sensing target, adjust the sensor to up or down, right or left. Then, fix the sensor in the center of position where the stability is operating.

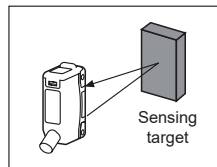

● Object (copper wire) detection <Micro spot type>

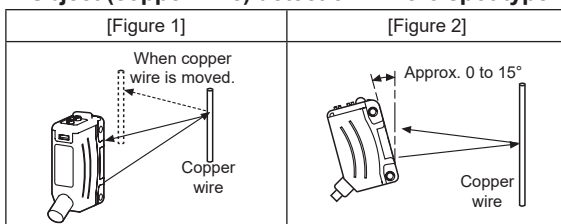

※Mount the sensor slanted at an angle ranged 0 to 15° shown above as [Figure 2] for stable detection to detect as shown in [Figure 1].

◎ Sensitivity adjustment

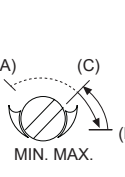
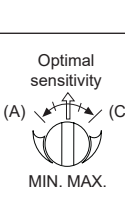
| Order | Position | Description |
|-------|---|--|
| 1 |  | Turn the sensitivity adjuster to the right of min. and check position (A) where the operation indicator is turned ON in "Light ON status". |
| 2 |  | Turn the sensitivity adjuster more to the right of position (A), check position (B) where the operation indicator is turned ON. And turn the sensitivity adjuster to the left, check position (C) where the operation indicator is turned OFF in "Light OFF status". ※If the operation indicator is not turned ON although the sensitivity adjuster is turned to the max. position, the max. position is (C). |
| 3 |  | Set the sensitivity adjuster at the center of (A) and (C). To set the optimum sensitivity, check the operation and lighting of stability indicator with sensing target or without it. If the stability indicator is not turned ON, please check the sensing method again because sensitivity is unstable. |

※No sensitivity adjustment function available for BJG30-DDT models.

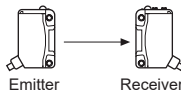
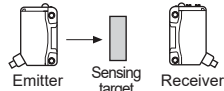
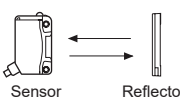
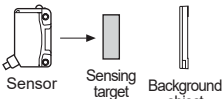
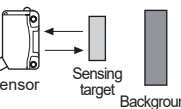
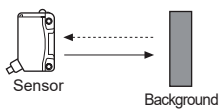
| | Light ON status | Light OFF status |
|------------------------------------|--|---|
| Through-beam type |  |  |
| Retro-reflective type |  |  |
| Diffuse/Narrow beam/BGS reflective |  |  |

※Set the sensitivity to operate in stable light ON area and the reliability for the environment (temperature, voltage, dust etc) is increased. In unstable light ON area, be sure to check the variation of environment.

※Do not apply excessive force on the sensitivity adjuster or operation mode switch, they may be broken.

※Please use reflective tape (MST Series) for where a reflector is not installed.

■ Reflectivity by Reflective Tape Model

| | |
|----------------------|------|
| MST-50-10(50×50mm) | 40% |
| MST-100-5(100×100mm) | 60% |
| MST-200-2(200×200mm) | 100% |

※This reflectivity is based on the reflector (MS-2A).

※Reflectivity may vary depending on usage environment and installation conditions.

The sensing distance and minimum sensing target size increase as the size of the tape increases.

Please check the reflectivity before using reflective tapes.

※For using reflective tape, installation distance should be min. 20mm.